

DETAIL 1
SCALE 1:2

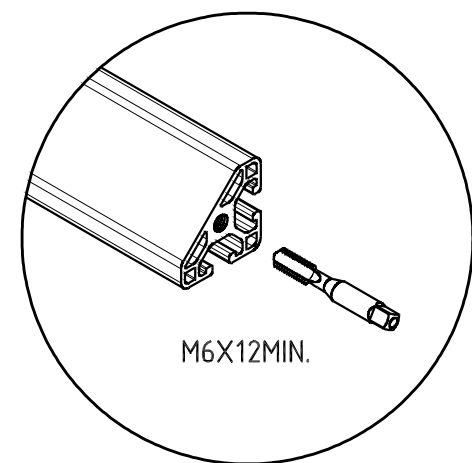

DETAIL 2
SCALE 1:2

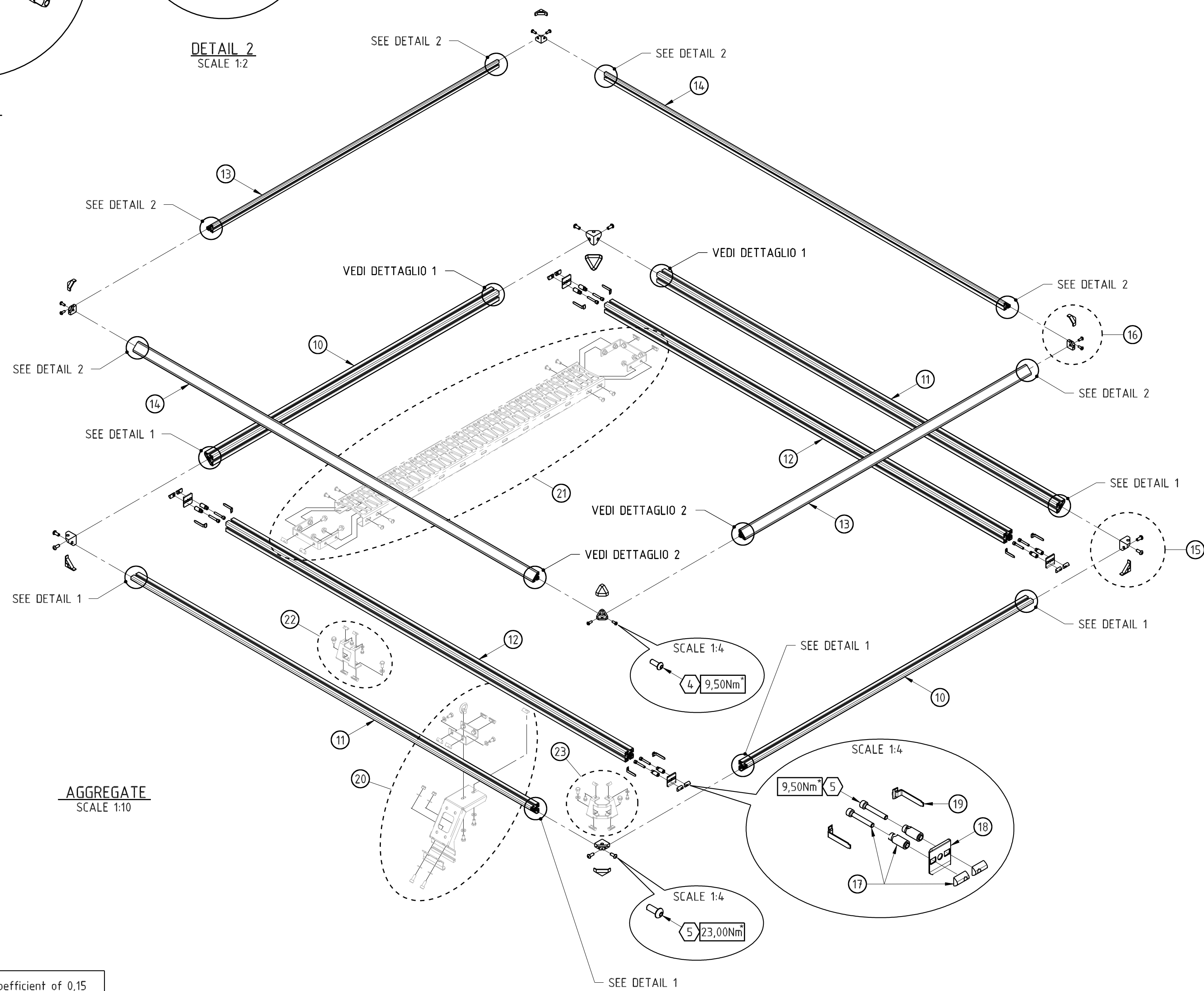

AGGREGATE
SCALE 1:10

* Considering a friction coefficient of 0,15

POSIZIONE	IDENTIFICATIVO	MATERIALE	STATO DI FORNITURA	LENGTH/Q.ty
10	TRANSVERSAL LOWER PROFILE	ALUMINUM ALLOY	SILVER ANODIZED	LENGTH=1360mm N°2 PIECES
11	EXTERNAL LONGITUDINAL LOWER PROFILE	ALUMINUM ALLOY	SILVER ANODIZED	LENGTH=SEE CHART N°2 PIECES
12	INTERNAL LONGITUDINAL PROFILE	ALUMINUM ALLOY	SILVER ANODIZED	LENGTH=SEE CHART N°2 PIECES
13	TRANSVERSAL UPPER PROFILE	ALUMINUM ALLOY	SILVER ANODIZED	LENGTH=1360mm N°2 PIECES
14	LONGITUDINAL UPPER PROFILE	ALUMINUM ALLOY	SILVER ANODIZED	LENGTH=SEE CHART N°2 PIECES
15	CORNER CONNECTION KIT	CARBON STEEL /ZINC ALLOY/POLYMER	WHITE ELECTROLYTIC GALVANIZED /PIANTED/BLACK	N°4 PIECES
16	CORNER CONNECTION KIT	CARBON STEEL /ZINC ALLOY/POLYMER	WHITE ELECTROLYTIC GALVANIZED /PIANTED/BLACK	N°4 PIECES
17	AUTOMATIC CONNECTION KIT	ACCIAIO AL CARBONIO	WHITE ELECTROLYTIC GALVANIZED	N°8 PIECES
18	SEAL	POLYMER	GRAY SIMILAR TO RAL 7042	N°4 PIECES
19	CAP	POLYMER	GRAY SIMILAR TO RAL 7042	N°8 PIECES
20	COMPONENT: LEG KIT ITEM PPKP	SEE ITEM SPECIFICS	SEE ITEM SPECIFICS	SEE TABLE
21	COMPONENT: CROSSBAR KIT ITEM PPKT	SEE ITEM SPECIFICS	SEE ITEM SPECIFICS	SEE TABLE
22	COMPONENT: INTERMEDIATE SPACER KIT ITEM PPKCI	SEE ITEM SPECIFICS	SEE ITEM SPECIFICS	SEE TABLE
23	COMPONENT: CORNER SPACER KIT ITEM PPKCC	SEE ITEM SPECIFICS	SEE ITEM SPECIFICS	SEE TABLE

BODY/EQUIPMENT	DESCRIPTION	PROFILES LENGTH	COMPONENTS Q.ty
VARIANT: PPKTA-1200 	-BODY TYPE: SWB CLOSED -ROOF RACK EQUIPMENT: HALF CAB -MAXIMUM MEASURES (inch): 47.2Length*56.7Wide*5.5Height	11 LENGTH=1120mm 12 LENGTH=1117mm 14 LENGTH=1120mm	-ITEM PPKP=N°4 PIECES -ITEM PPKT=N°4 PIECES -ITEM PPKCC=N°4 PIECES -ITEM PPKCI=N°4 PIECES
VARIANT: PPKTA-1900 	-BODY TYPE: SWB CLOSED -ROOF RACK EQUIPMENT: FULL CAB -MAXIMUM MEASURES (inch): 74.8Length*56.7Wide*5.5Height	11 LENGTH=1820mm 12 LENGTH=1817mm 14 LENGTH=1820mm	-ITEM PPKP=N°6 PIECES -ITEM PPKT=N°6 PIECES -ITEM PPKCC=N°4 PIECES -ITEM PPKCI=N°4 PIECES
VARIANT: PPKTA-2350 	-BODY TYPE: LWB CLOSED -ROOF RACK EQUIPMENT: FULL CAB -MAXIMUM MEASURES (inch): 92.5Length*56.7Wide*5.5Height	11 LENGTH=2270mm 12 LENGTH=2267mm 14 LENGTH=2270mm	-ITEM PPKP=N°8 PIECES -ITEM PPKT=N°8 PIECES -ITEM PPKCC=N°4 PIECES -ITEM PPKCI=N°6 PIECES

The summary table provides guidelines for the construction of modular roof racks in measures tested by us, on various standard production body. For custom equipments or specific requirements we are available to provide any kind of support or technical information.

		TABLE: n°01	SHEET: A2L SCALE 1:10 - 1:4 - 1:2
		AGGREGATE	
TECHNICAL DRAFTSMAN:	MARCO ACERBIS	ITEM CODE:	PPKTA
IDENTIFICATION:	ROOF RACK FRAME KIT TYPE HIGH		

La proprietà di questo disegno è tutelata a termini di legge. È vietato utilizzarlo, riprodurlo o divulgarlo senza il permesso di G.F. FREANI COSTRUZIONI METALLICHE